

Appendix A

Field Survey Data Dictionary

Field Survey Data Dictionary

BUS STOP ASSESSMENT

Longitude

Generated by GPS receiver and manually checked for accuracy.

Latitude

Generated by GPS receiver and manually checked for accuracy.

Stop ID

A unique value that is assigned to each bus stop. This value is either taken from the bus stop sign or manually generated.

On Street

On Street is the name of the street the bus is stopped on when serving the stop.

Cross Street

Cross Street is the closest cross street. It may, on occasion, be an address, business name or a descriptor, such as "EAST END OF RAIL OVERPASS" or "WALMART".

Heading

Heading is the direction a bus would be facing when stopped at the bus stop (360=North, 90=East, 180=South, 270=West). Expressed in decimal degrees. Range: 0-360.

Placement

Identify the location of the bus stop relative to the Cross Street.

Valid designations are:

1. Nearside
2. Farside
3. Mid-block
4. Across From
5. At Location

Speed Limit

Identify the posted speed limit for the roadway adjacent to the bus stop.

Valid designations are:

- 10 mph
- 25 mph
- 30 mph
- 35 mph
- 40 mph
- 45 mph
- 50 mph
- 55 mph
- 60 mph
- 65 mph
- Not Applicable

Travel Lanes

Identify the number of travel lanes along the roadway adjacent to the bus stop.

Valid designations are:

- 1
- 2
- 3
- 4
- 5
- 6+
- Not Applicable

Median

Identify if there is a raised median or pedestrian refuge island across the on-street.

Valid designations are:

- Yes
- No

Bus Stop Signage

Identify the number of a head signs at the stop.

Valid designations are:

- 0
- 1
- 2
- 3

Bus Stop Owner

Identify the owner of each head sign.

Valid designations are:

- Annapolis Transit
- Charm City Circulator
- Harford LINK
- MTA Commuter Bus
- MTA LINK
- RTA of Central Maryland
- Queen Anne's County Commuter
- Other

Sign Installation

Identify how the bus stop sign is installed at the bus stop.

Valid designations are:

- Bus Stop pole
- Traffic sign pole
- Utility pole
- Light pole
- Shelter
- Building
- Traffic light pole
- Other

Sign Height

Identify if the distance from the bottom of the sign to the ground is greater or less than 80 inches.

Valid designations are:

- Less than 80”
- 80” or greater

Route Information

Document the route information that is posted on the bus stop sign. Separate route numbers with a comma. Leave blank if there is not route information on the bus stop sign. Free form text.

Contact or Bus Tracker Information on Sign

Identify if there is a phone number on the bus stop sign.

Valid designations are:

- Yes
- No

Sign or Pole Damage

Identify if there is any physical damage to the bus stop pole.

Valid designations are:

- None
- Rust
- Bent
- Severed
- Graffiti
- Loose
- Leaning
- Other

Sign or Pole Comments

Freeform notes field to capture any miscellaneous comments.

Information Case

Identify if there is an information case at the bus stop.

Valid designations are:

- Yes
- No

Information Case Accessible

Identify if the information case is accessible meaning there is a paved unobstructed 36” area around the information case.

Valid designations are:

- Accessible
- Obstructed
- Unpaved
- Not Applicable

Information Case Damage

Identify if there is any physical damage to the information case.

Valid designations are:

- None
- Loose
- Graffiti
- Stickers
- Broken
- Other

Digital Display

Identify if there is a digital information display at the bus stop.

Valid designations are:

- Yes
- No

Route Schedule

Identify if there is a schedule of the route available at the bus stop.

Valid designations are:

- Yes
- No

Route Map

Identify if there is a map of the route available at the bus stop.

Valid designations are:

- Yes
- No

System Map

Identify if there is a map of the system map available at the bus stop.

Valid designations are:

- Yes
- No

Bus Stop Lighting

Identify if there is lighting within 30 feet of the bus stop location.

Valid designations are:

- Yes
- No

Trash Can

Identify if there is a trash receptacle at the bus stop.

Valid designations are:

- Yes
- No

Trash Can Comments

Freeform notes field to capture miscellaneous information about trash-related issues.

Vendor Publication Box

Identify the number of vendor publication boxes at the bus stop.

Valid designations are: 0-10

Vendor Publication Box Comments

Freeform notes field to capture miscellaneous information about vendor box issues.

Bike Racks

Identify if there are bike racks at the bus stop.

Valid designations are:

- Yes
- No

Shelter Count

Identify the number of shelters at bus stop.

Choice variable is 0-5.

Shelter Foundation

Identify the type of surface the shelter is mounted on.

Valid designations are:

- Concrete
- Brick
- Dirt
- Stone
- Grass
- Other

Shelter Damage

Identify any physical damage to the shelter.

Valid designations are:

- None
- Loose
- Panel
- Graffiti
- Rust
- Roof
- Stickers
- Other

Shelter Access

Identify if there is unobstructed access to the entrance of the shelter.

Valid designations are:

- Yes
- No

Shelter Entrance

Is there an opening at the front of the shelter that is at least 36” wide and obstructed?

Valid designations are:

- Yes
- No

Shelter Interior

Identify if there is an unobstructed space completely under the shelter that is at least 30” wide by 48” deep.

Valid designations are:

- Yes
- No

Shelter Comments

Freeform text field to capture any miscellaneous information about shelters.

Bench

Identify the number of benches at the bus stop.

Choice variable is 0-10.

Bench Location

Identify the location of the bench(es).

Valid designations are:

- Shelter
- Freestanding
- Shelter and Freestanding

Bench Damage

Identify any physical damage to the bench.

Valid designations are:

- None
- Broken Pieces
- Graffiti
- Poor Installation
- Other

Bench Comments

Freeform text field to capture any miscellaneous information about the benches.

Landing Pad

Identify if there is a presence of a 5' x 8' non-dirt paved ADA landing pad at the bus stop.

Valid designations are:

- None
- Yes, unobstructed
- Yes, obstructed
- No, <5'x8'
- No, Sidewalk

Landing Pad Material

Identify the surface material of the landing pad.

Valid designations are:

- Concrete
- Asphalt
- Brick Pavers
- Other

Landing Pad Surface Problem

Identify if the landing pad have problems that could impede its use by pedestrians or persons with a mobility device.

Valid designations are:

- None
- Major cracks
- Uneven pavement
- Vegetation
- Slope
- Catch basin
- Other

Landing Pad Obstruction

Identify if there is a potential obstruction on the landing pad area that would make it less than 5' x 8'.

Valid designations are:

- None
- Trash Can
- Shelter
- Utility Pole
- Bus Stop Pole
- Traffic Sign Pole
- USPS Mailbox
- Fence
- Wall
- Other

Landing Pad Connect to Sidewalk

Identify if the landing pad is connected by a sidewalk.

Valid designations are:

- Yes
- No
- Not Applicable (there's a pad but no sidewalk)

Landing Pad Connect to Curb

Identify if the landing pad connects to the on-street curb.

Valid designations are:

- Yes
- No
- Not Applicable (no curb)

Landing Pad Comments

Freeform comments field to capture any miscellaneous information about the landing pad.

Sidewalk Width

Document the width of the sidewalk in inches. If no sidewalk is present enter "None". Free form text field.

Sidewalk Landscape Buffer

Identify if there is a presence of landscaping/grassy area between the sidewalk and the curb.

Valid designations are:

- Yes
- No

Sidewalk Obstruction

Identify if there is an object along the sidewalk between the bus stop and the nearest intersection that reduces the sidewalk width to less than 48”.

Valid designations are:

- None
- Vendor Publication Box
- Utility Pole
- Shelter
- Bench
- Trash Can
- Landscaping
- Fence
- Wall
- Mailbox
- Street Sign Pole
- Bus Stop Pole
- Other

Sidewalk Surface Problem

Identify if there is an impediment that could make travel along the sidewalk difficult and/or unsafe.

Valid designations are:

- None
- Major cracks
- Uneven pavement
- Vegetation
- Slope
- Sink hole
- Other

Curb Ramp Type

Identify the type of curb ramp that is closest to the bus stop.

Valid designations are:

- None
- Perpendicular
- Diagonal
- Parallel

Detectable Warning

Identify if there is a detectable warning surface on the curb ramp closest to the bus stop.

Valid designations are:

- Yes
- No

Curb Ramps

The following four fields are designed to determine if there are connecting curb ramp pairs at the stop in the location specified – On-street/Nearside, On-street/Farside, At-street/At Stop, or At Street/Opposite Side.

Curb Ramp Connection OSNS

Curb ramp connection at the on-street nearside intersection crossing location.

Valid designations are:

- Yes
- No
- Not Applicable

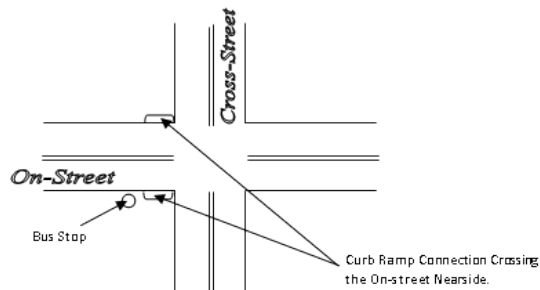

Curb Ramp Connection OSFS

Curb ramp connection at the on-street farside intersection crossing location.

Valid designations are:

- Yes
- No
- Not Applicable

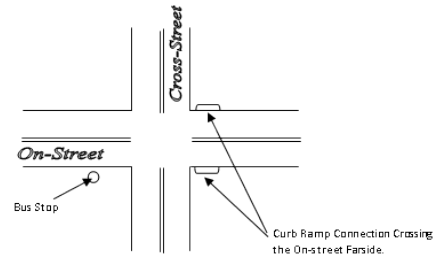

Curb Ramp Connection CSAS

Curb ramp connection for the cross-street on the side of the onstreet where the bus stop is located.

Valid designations are:

- Yes
- No
- Not Applicable

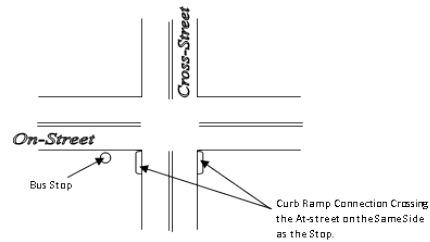

Curb Ramp Connection CSOP

Curb ramp connection for the cross-street on the opposite side of the onstreet where the bus stop is located.

Valid designations are:

- Yes
- No
- Not Applicable

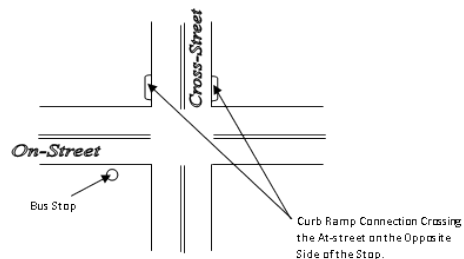

Crosswalks

The following four fields are designed to determine if there are marked crosswalks at the stop in the location specified – On-street/Nearside, On-street/Farside, At-street/At Stop, or At Street/Opposite Side.

Crosswalk OSNS

Marked crosswalk along the on-street (the street the bus is traveling on) nearside of the intersection or stop (if it is a mid-block stop).

Valid designations are:

- Yes
- No
- Not Applicable

Crosswalk OSFS

Crosswalk that cross the on-street (the street the bus is traveling on) farside of the intersection.

Valid designations are:

- Yes
- No
- Not Applicable

Crosswalk CSAS

Crosswalk that cross the cross-street on the same side of the street as the bus stop location.

Valid designations are:

- Yes
- No
- Not Applicable

Crosswalk CSOP

Crosswalk that cross the cross-street on the opposite side of the intersection where the bus stop is located.

Valid designations are:

- Yes
- No
- Not Applicable

Traffic Control Device OS

Identify if there is a traffic control device for the on-street at the intersection nearest the bus stop.

Valid designations are:

- Traffic Light
- Stop Sign
- Yield Sign
- None
- Not Applicable

Traffic Control Device CS

Identify if there is a traffic control device for the cross-street at the intersection nearest the bus stop.

Valid designations are:

- Traffic Light
- Stop Sign
- Yield Sign
- None
- Not Applicable

Pedestrian Control OS

Identify if there is a pedestrian crossing signal to cross the on-street.

Valid designations are:

- Yes
- No
- Not Applicable

Pedestrian Control CS

Identify if there is a pedestrian control signal to cross the cross-street.

Valid designations are:

- Yes
- No
- Not Applicable

WAYFINDING SIGNAGE INVENTORY

Longitude

Generated by GPS receiver and manually checked for accuracy.

Latitude

Generated by GPS receiver and manually checked for accuracy.

Sign Information

Document the information conveyed by the sign. Free from text field.

CURB RAMPS

Longitude

Generated by GPS receiver and manually checked for accuracy.

Latitude

Generated by GPS receiver and manually checked for accuracy.

Heading

Directional heading. For curb ramps, the heading is determined based on the direction of vehicle traffic perpendicular to the sidewalk; for diagonal curb ramps base the heading on the direction of travel of the larger road. For intersections and pathways, heading is determined based on the evaluator's direction of travel.

Valid designations are:

- North
- South
- East
- West
- Southwest
- Southeast
- Northeast
- Northwest

Position

Position of curb ramp relative to intersection, based on the direction of vehicle traffic. Nearside is prior to reaching an intersection. Farside is after passing through the intersection.

Valid designations are:

- Nearside
- Farside
- Midblock

Placement

Identifies location of curb ramp. Valid designations are:

- Block
- Block Corner
- Median
- Side Island
- Side Island SL – (Slip Lane)
- Driveway

Type

Identifies the type of curb ramp design. Valid designations are:

- Perpendicular
- Diagonal
- Parallel
- Depressed Corner/Blended Transition
- Modified (Other)

Companion Ramp

Identifies if there is an accessible transition on the opposite side of the intersection (i.e. Can a person in a wheelchair exit off the opposite side of the street?) Valid designations are:

- Yes
- No
- N/A

Sidewalk Connection

Identifies if the curb ramp is connected to a sidewalk? Valid designations are:

- Yes
- No

Tactile Surfaces

Identifies the presence of raised features across the curb ramp that provide a detectable warning for the visually impaired. Valid designations are:

- Yes, Placed Correctly
- Yes, Not Placed Correctly
- No

Ramp in Marked Crosswalk

Identifies if the bottom of the curb ramp is within a marked crosswalk. Valid designations are:

- Yes
- No
- No Marked Crosswalk

Bottom Space

Length of the level area within the crosswalk at the bottom of the curb ramp, measured from the street-gutter interface to the edge of the marked crosswalk. Valid designations are:

- $\geq 48''$
- $< 48''$
- N/A

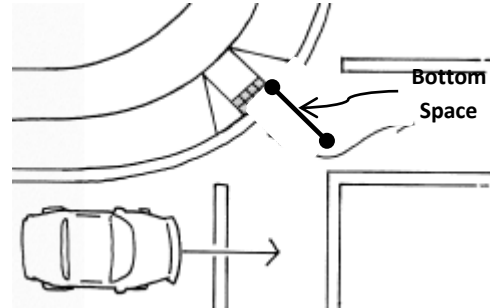

Ramp Width

Width of curb ramp along edge of street. Measurements do not include flares. Valid designations are:

- $< 48''$
- $\geq 48''$

Top Landing Size

Identifies size of landing at top of the curb ramp. Valid designations

- None
- $\geq 48'' \times 48''$
- $< 48'' \times 48''$

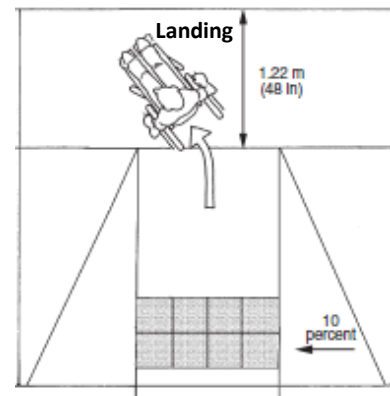

are:

Ramp Running Slope

Slope of the curb ramp in the direction of pedestrian travel. Valid designations are:

- $\leq 5\%$
- 5.1% to 8.3%
- 8.4% to 10%
- $> 10\%$

Ramp Cross Slope

Slope of the ramp perpendicular to the direction of pedestrian travel. Valid designations are:

- $\leq 2\%$
- $> 4\%$

Flare Slopes

Slope of the flares connecting the ramp to the sidewalk. Valid designations are:

- $\leq 8.3\%$
- 8.4% to 10%
- $>10\%$
- No Flare

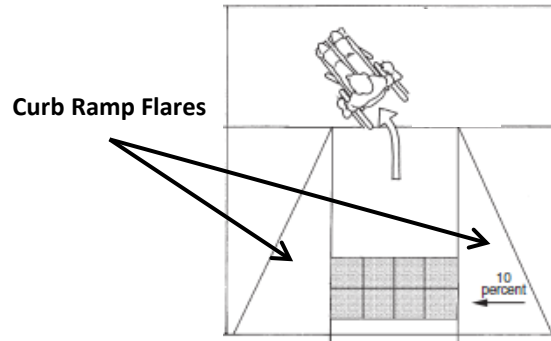

Top Landing Cross Slope

Slope of the area at the top of the curb ramp, measured perpendicular and parallel to a pedestrian walking up the curb ramp. Valid designations are:

- $\leq 2\%$
- 2.1% to 4%
- 4.1% to 10%
- $> 10\%$
- "Null"

Transition

Identifies if the curb ramp is flush with the top landing. Valid designations are:

- Flush
- Not Flush
- N/A

Perpendicular

Identifies if the curb ramp has an even perpendicular surface transition with the top landing. Valid designations are:

- Perpendicular
- Not Perpendicular
- N/A

Bottom Surface Counter Slope

Identifies the counter slope of the street surface/gutter at the grade break of the ramp. It is the slope opposite the curb ramp slope. Valid designations are:

- $\leq 5\%$
- $> 5\%$



INTERSECTIONS

Longitude

Generated by GPS receiver and manually checked for accuracy.

Latitude

Generated by GPS receiver and manually checked for accuracy.

Traffic Control

What type of traffic control measure are present at the intersection? Valid designations are:

- Traffic Light
- Stop Sign
- Round-a-Bout
- None
- N/A

Marked Crosswalk

Is there a distinct material used to demarcate crosswalk at intersections and mid-block crossings. Valid designations are:

- Yes
- No
- Damaged/Faded
- "Null" – (e.g. under construction)

Curb Ramp Connection

Identifies the presence of connected companion curb ramps on either end of the intersection segment. Valid designations are:

- Yes
- No
- N/A

Presence of Pedestrian Refuge Island

Identifies the presence and type of pedestrian refuge island. Valid designations are:

- None
- Median Island
- Side Island

Pedestrian Refuge Island Length

Length of the pedestrian refuge island in the direction of pedestrian travel. Valid designations are:

- None
- <6'
- >=6'

Pedestrian Refuge Island Tactile Surface

Presence of truncated domes on curb ramps or cut-throughs on refuge islands. Valid designations are:

- One Side
- Both Sides
- None
- N/A

Pedestrian Signal Countdown

Identifies whether a pedestrian signal provides a countdown to assist pedestrians in determining how much time is available to safely cross the street. Valid designations are:

- Yes
- No
- "Null"

Pedestrian Signal Audible

Identifies whether a pedestrian signal provides audible sounds or instructions to assist the visually impaired. Valid designations are:

- Yes
- No
- "Null"

Pedestrian Signal Button Accessible

Identifies whether there is a flat landing 48" by 48" that allows individuals with limited mobility to press the pedestrian signal button. Valid designations are:

- Yes
- No
- "Null"

Pedestrian Signal Button Height

Height from ground (improved surface) to the middle of button measured in inches. Valid designations are:

- <15"
- 15" to 48"
- >48"

SIDEWALK BARRIERS

Longitude

Generated by GPS receiver and manually checked for accuracy.

Latitude

Generated by GPS receiver and manually checked for accuracy.

Barrier

Identifies each sidewalk barrier along the pathway between transfer stops. Valid designations are:

- Cross Slope
- Obstruction
- Protrusion
- Running Slope
- Surface Gap
- Vertical Elevation

