

AMENDMENT

Baltimore Region FY 2011-2014

Transportation Improvement Program (TIP)

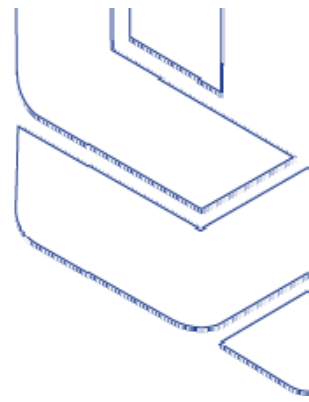

Improving our Regions Highways & Byways

Public Meeting – I-695 & Areawide Projects
Arbutus, MD – May 16, 2011



Baltimore Metropolitan Council



Who We Are

- BRTB - Baltimore Regional Transportation Board
- Metropolitan Planning Organization for the Baltimore region.
- Staff support provided by the Baltimore Metropolitan Council.

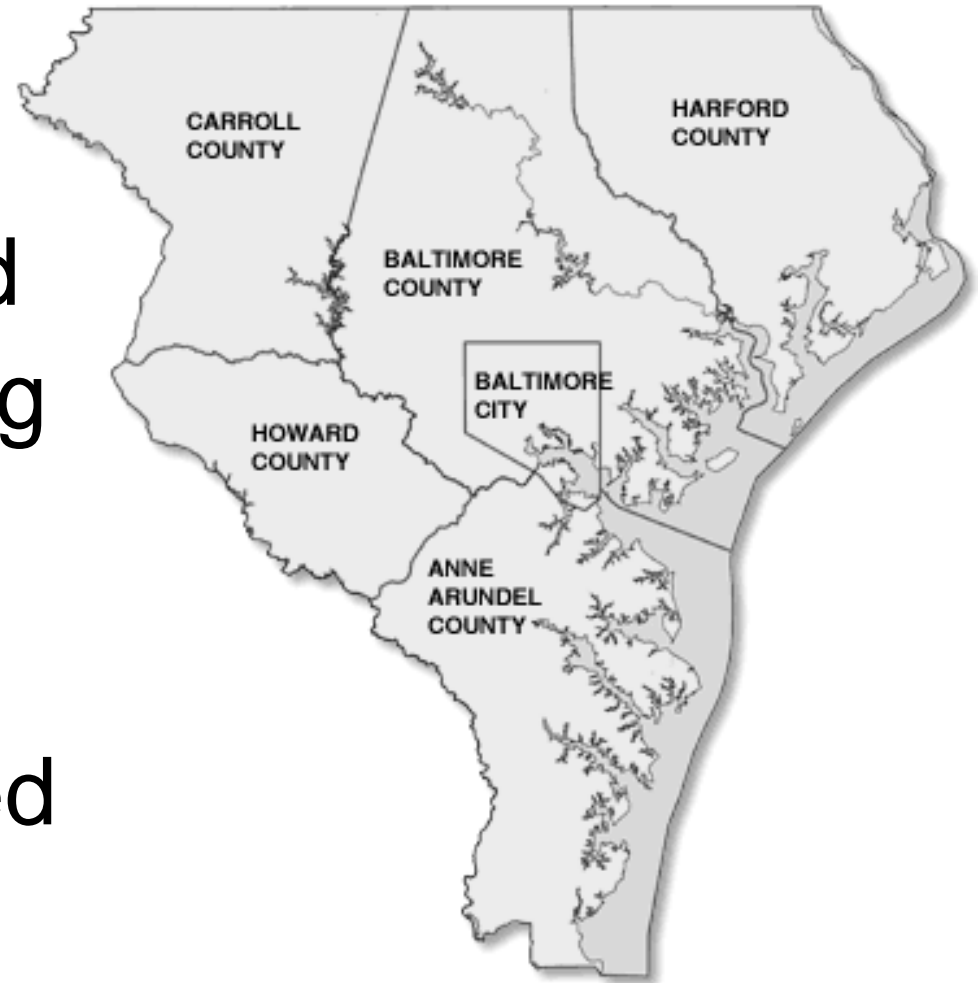

BRTB Members

- City of Annapolis – Joshua J. Cohen, Mayor
- Anne Arundel County - John R. Leopold, County Executive
- City of Baltimore - Stephanie Rawlings-Blake, Mayor
- Baltimore County - Kevin Kamenetz, County Executive
- Carroll County - Haven Shoemaker, Member, Board of Commissioners
- Harford County - David R. Craig, County Executive
- Howard County - Ken Ulman, County Executive

- MD Department of Transportation - Beverley Swaim-Staley, Secretary
- MD Department of the Environment - Robert Summers, Secretary
- MD Department of Planning - Richard E. Hall, Secretary
- MD Transit Administration - Ralign T. Wells, Administrator and CEO



What The BRTB Does

Planning & Analysis for:

- Air Quality
- Bicycle and Pedestrian
- Emergency Preparedness
- Freight
- Safety
- Transit



What The BRTB Does

- Annual work program
- Short-term transportation program (TIP)
- Long-range Transportation Plan
- Air quality assessments of all transportation projects



What is the Transportation Improvement Program (TIP)?

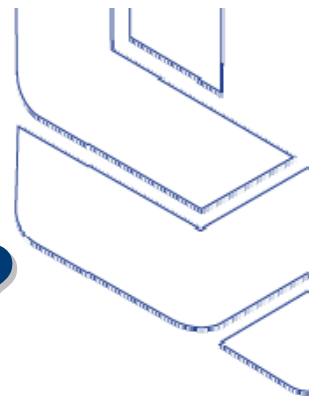

- Short-range (four-year) program of transportation improvements & priority projects.
- Authorization to seek federal funds
- Financially constrained
- Updated annually: Current is FY 2011-2014.
- Amendments require 30-day public review
 - New projects, New funding, etc
- Similar to the local CIP or state CTP



Air Quality Assessment

- TIP and long-range plan go through a process that compares estimated pollutants (emissions) from transportation projects to limits (budgets) set by the State.
- This report, called a “conformity determination”, addresses fine particulate matter (PM2.5), 8-hour ozone and CO standards.



What's Being Amended?

I-695: I-95 (SW) to MD 122

- **New:** \$1 million added to design a new ramp connection to the Inner Loop of I-695 near Leeds Ave and US 1 in Arbutus.
- **Existing:** A study looking at possibly expanding west side of the Baltimore Beltway from 6 to 8 lanes.
- Project web site:
<http://apps.roads.maryland.gov/WebProjectLifeCycle/ProjectInformation.aspx?projectno=AW758213>



I-695 Project Details

- Design to begin Summer 2011
- Purpose - To improve access to the Inner Loop of I-695 in the vicinity of Arbutus as well as the:
 - MARC station
 - Arbutus Volunteer Fire Department (on US 1)
- Project will provide a new I-695 On-Ramp to provide access to Inner Loop of I-695 near Leeds Avenue & US 1 (Southwestern Blvd).

I-695 Project Details

- New ramp will replace the existing ramp connection from Leeds Avenue to I-695 Inner Loop
 - Removes direct connection from Leeds Avenue to the Inner Loop of I-695
 - New ramp connection, from US 1 over Leeds Avenue, to the Inner Loop of I-695



I-695 Project Details

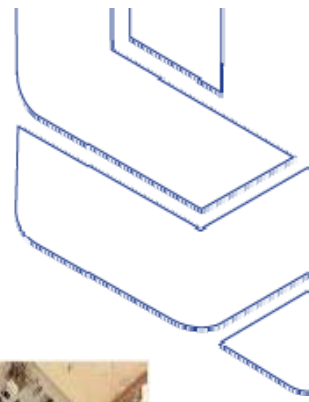

What Else is Being Amended?

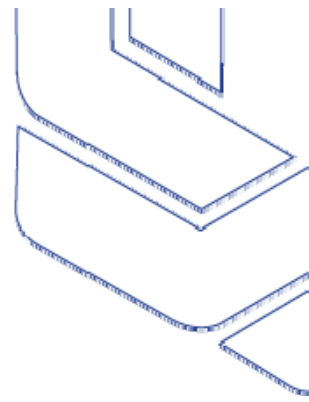

Areawide Projects

Increases funding in 3 areas:

1. Congestion Management
2. Safety and Spot Improvements
3. Environmental Projects



Congestion Management

- \$1.95 million - Install CCTV cameras and other congestion management strategies
- \$0.5 million - Design for Park & Ride lot expansions:
 - US 50 @ MD 424
 - MD 4 @ MD 408



Safety & Spot Improvements

\$4.4 million

- Installation of UPS/LED lights (uninterrupted power supply/light emitting diode)
- Sidewalk improvement projects to meet ADA standards.



Environmental Projects

\$13.4 million total: \$4.5M for Design, \$400,000 for Project Planning and \$8.5M for Construction

- Training, compliance, monitoring and research of the Total Maximum Daily Load (TMDL) requirements
- Installation of trees
- Pavement remedial projects with contracts
- Construction support
- Installation of SWM facilities



Your Comments Welcome!

Comments welcome through Monday, June 6, 2011

Baltimore Regional Transportation Board
1500 Whetstone Way, Suite 300
Baltimore, MD 21230

410-732-8248 (Fax)

comments@baltometro.org

www.baltometro.org/bboard



For More Information

Damilola Kehinde

MD State Highway Administration

410-545-5560 | dkehinde@sha.state.md.us

Regina Aris

Baltimore Metropolitan Council

410-732-9572 | raris@baltometro.org