

SIEMENS

Intelligent Transportation Systems

Benefits of Standardization – Traffic Signal Control

Baltimore Regional Traffic Signal Forum

March 14, 2007

Diederick VanDillen

ITS Standards Landscape

Communication

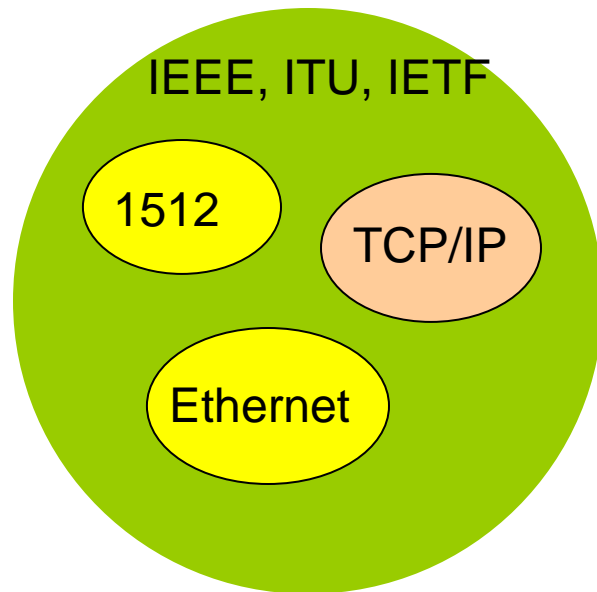

Why are standards needed?

Transportation

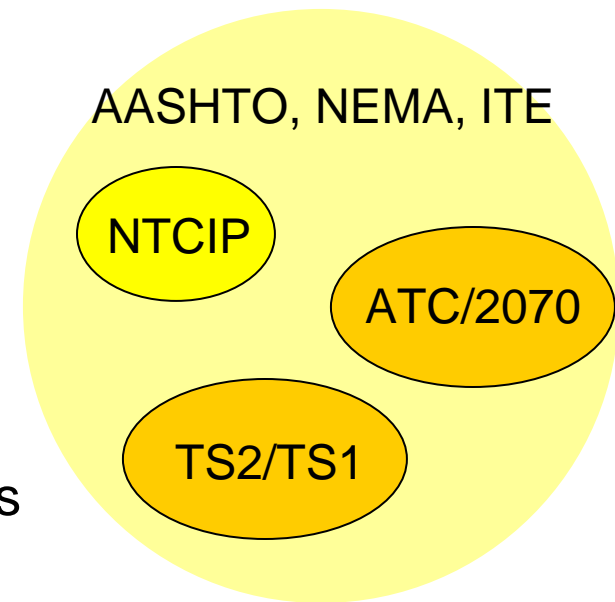

What standards should I consider?

Why use Standards?

- Defines open and standard hardware and software interface; and method for communications and information exchange
- Supports integration of different vendor products promoting vendor interoperability and neutrality
- Allows for modular design of systems to isolate against future obsolescence, and accommodate change
- Federally – funded ITS projects must conform to the Regional ITS Architecture (2005) and NTCIP
- Don't "Reinvent the Wheel" – Plenty to choose from – Possible that someone else has already developed what is needed

Formal Standards

- Developed through standards body (ITE, NEMA, AASHTO, IEEE)
 - ITE – ITS standards
 - NEMA – controllers, field hardware, NTCIP
 - IEEE – communications (Ethernet), 1512 (incident management)
- Widespread industry (public/private) involvement – consensus driven results
- Limited funding and mostly voluntary effort – sometimes standards can lag market demand
- Standards body may function as arbitrator

DeFacto Standards

- Vendor developed and owned but is so widespread it is considered a standard (i.e. MS Windows)
- Single vendor, least competitive environment, with widespread market acceptance and use
- No control over product changes, modifications

Open Standards

- Developed through informal community consortium (i.e. Linux, Caltrans AB3418, SHA CHART).
- User community developed, open, published standard
- Open Source
- More informal than other standards

Components of an Integrated ATMS

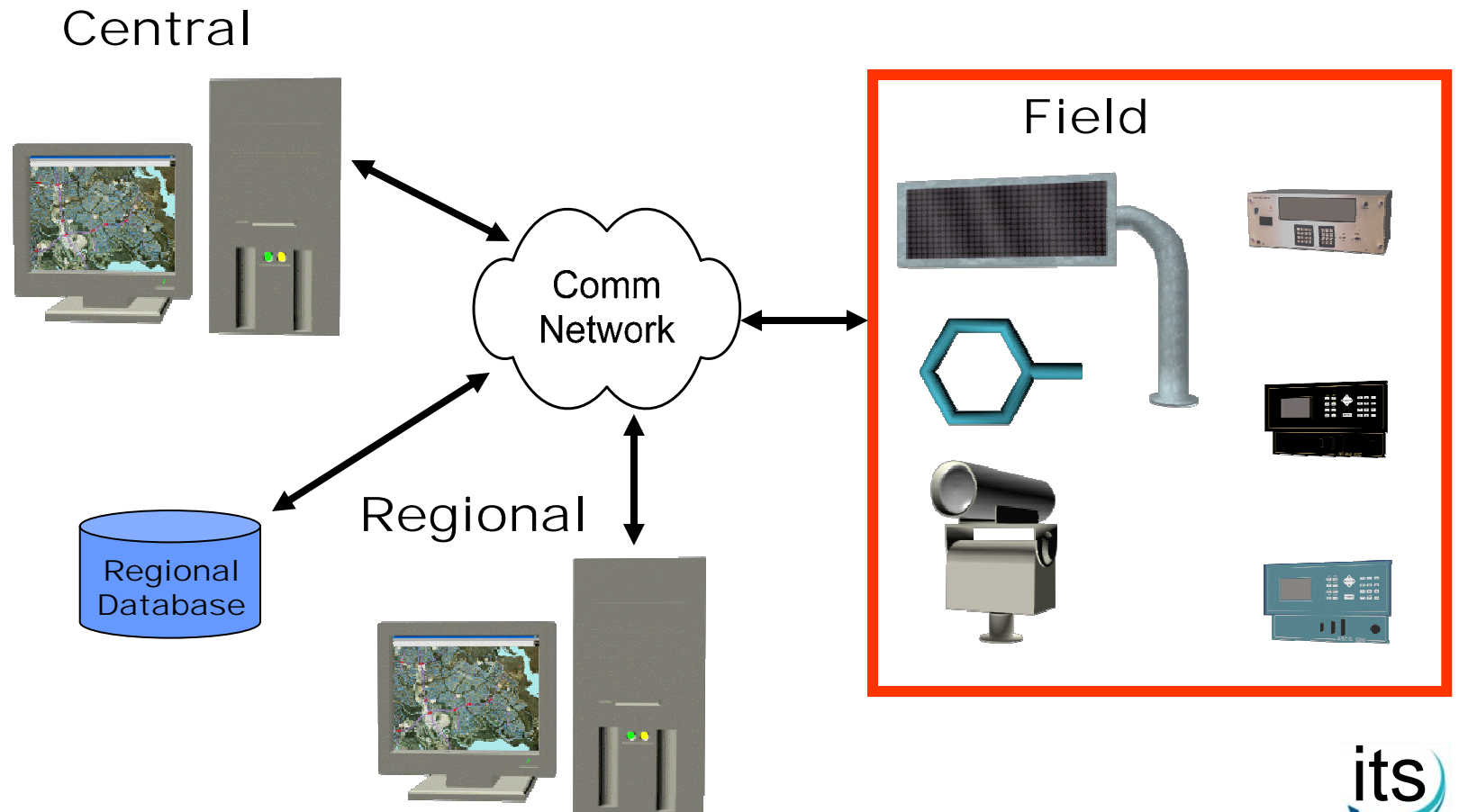

Field Equipment – Cabinets/Controllers

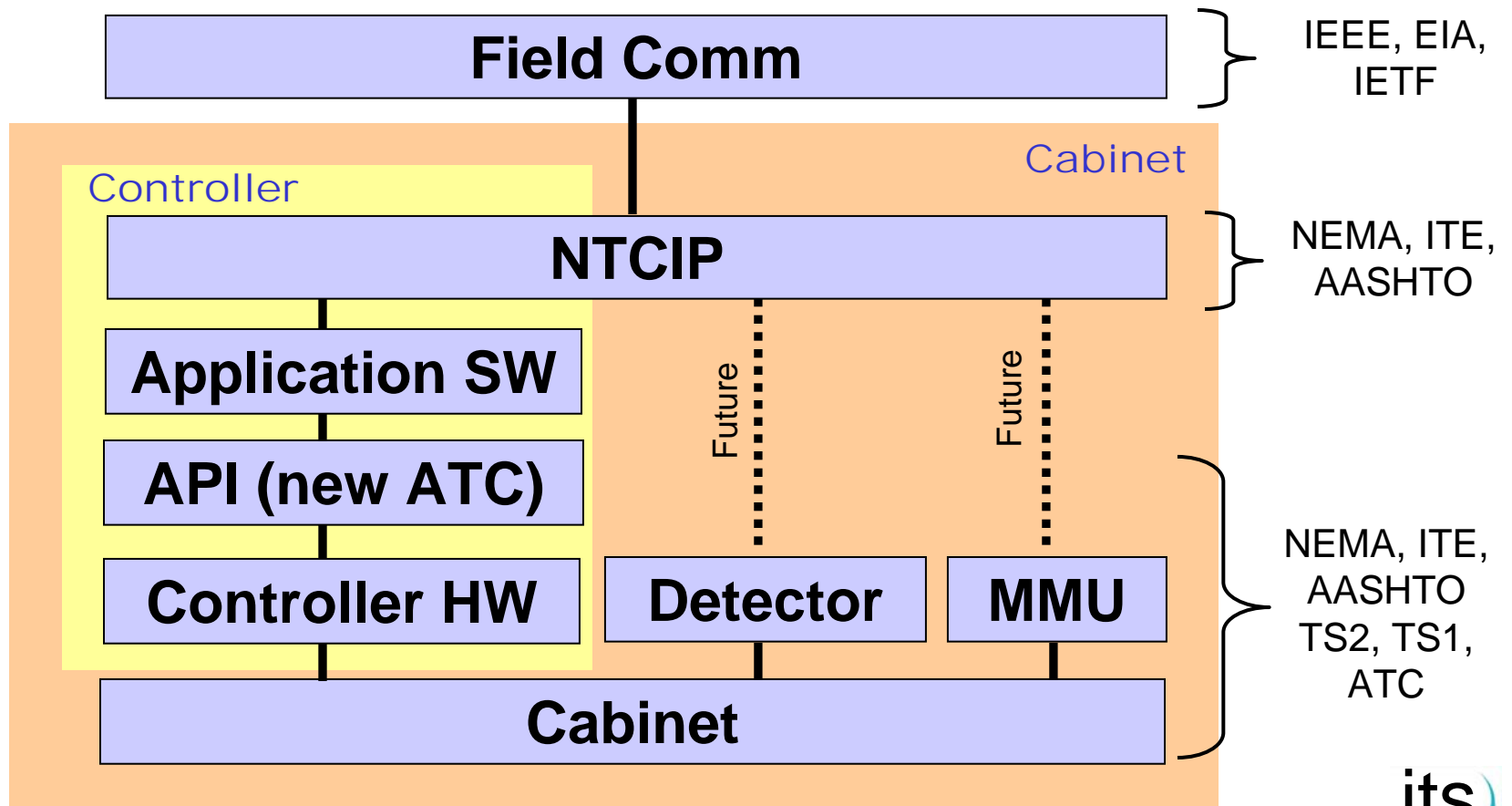

Central and Regional Equipment

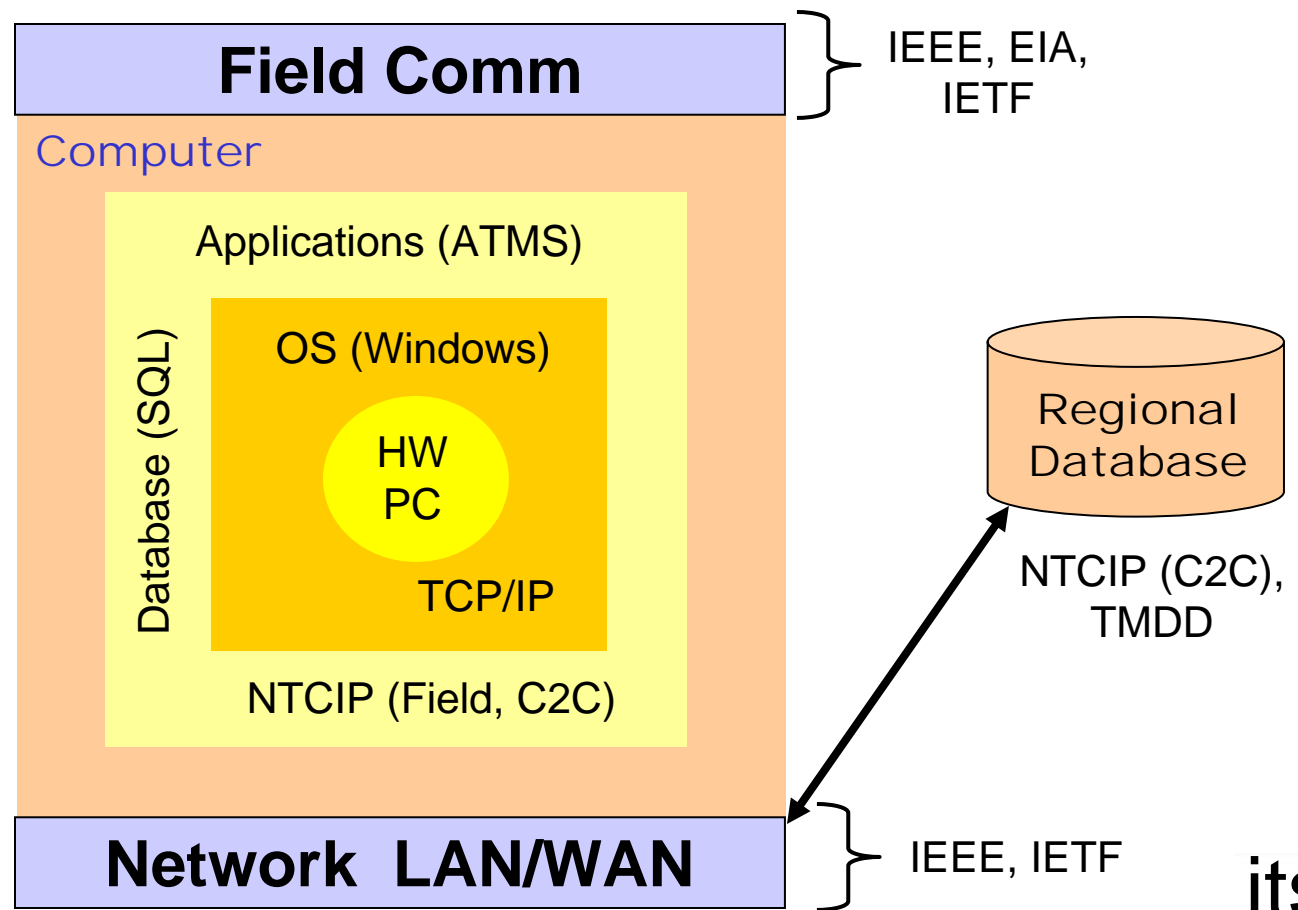

Advantages

- Standards define minimum level of interoperability, interchangeability, and functionality
- Interoperability – ability of multiple different device types to seamlessly work together (i.e. share comm. channel)
- Interchangeability – ability for devices of the same type to be exchanged for another device of the same type (controllers)
- Vendor extensions allow for innovation to keep pace with technology or new functional features

Advantages

- Standard maintained by standards body (formal) with process for review, approval, updates, arbitration
- Reduced system integration development time and cost
- No Licensing and IP access rights restrictions
- Independent compliance testing
- Availability of development and verification tools

Disadvantage of Standards

- Can lag industry/proprietary solutions (i.e. NTCIP field master and signal control priority)
- Vendor-specific extensions can affect:
 - Interchangeability
 - System integration complexity – less open solution
 - Maintenance costs – less control over the interface
 - Licensing and access restrictions to proprietary information

Disadvantage of Standards

- Implementation may not be as efficient as proprietary solution (i.e. NTCIP communication channel loading)
- May not support necessary capabilities – either standard not developed, not mature, or features/functions not included
- May include features/functions not needed – may impact cost, performance

Systems Design Process

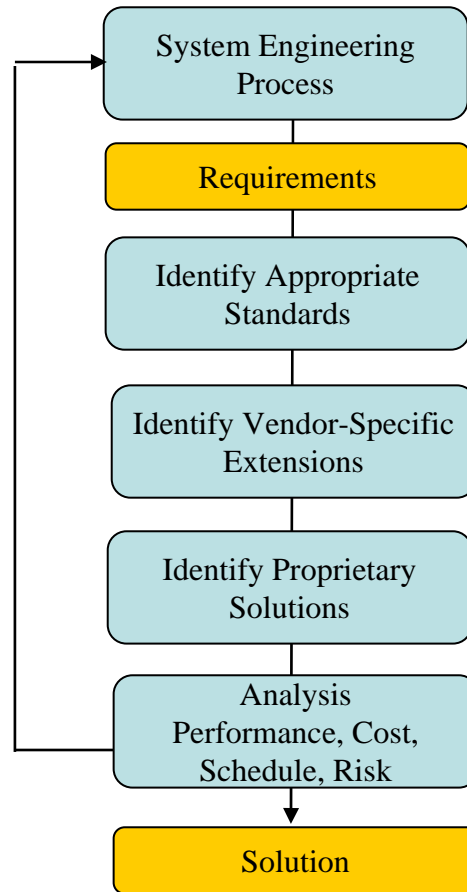

Design & Implementation Issues

- Modular design to limit impact of changes – technology continues to advance
- Use standards where possible
- Standards Stability – greater risk in implementing newer standards
- Adopting future standards amendments – maintenance, upgrades
- Standards interpretation resolution

Design & Implementation Issues

- Conformance and certification – increases cost but decrease risk
- Interoperability testing and integration with other components
- Performance issues – standards often trade off performance (computer processing, communications bandwidth) for generic solution

Design & Implementation Issues

- Technology Trends to Consider
 - Distributed processing puts more intelligence at the field level – cabinets/controllers becoming processing hubs
 - Increase in communication bandwidth needs
 - Ethernet, TCP/IP as transport follows IT trends

Resources

- ITS
 - ITE – www.ite.org/standards
 - NEMA Published Standards: www.nema.org
 - NTCIP Guide, Standards, and Working Groups: www.ntcip.org
 - ITSA Architecture and Standards forums: www.itsa.org
- Communication
 - IEEE Communication: www.ieee.org
 - IETF Internet: www.ietf.org