

# CMAQ Update

*Progress of 2008 and 2009 Projects*

*November 24, 2009*



Baltimore Metropolitan Council



# BRTB CMAQ Process

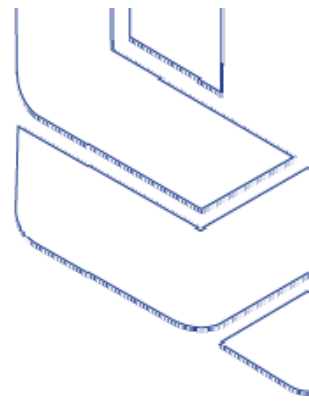

- FY 2008 Competitive Selection:
  - 6 projects selected – 4 have received federal approval and are moving forward
- FY 2009 Competitive Selection:
  - 4 projects selected – 3 have received federal approval and are moving forward

# Southeast Baltimore TMA

- Formal agreement between City of Baltimore and Waterfront Partnership
- Steering Committee meeting regularly
- As of September 2009:
  - \$40,000 of \$200,000 spent
  - Public launch of TMA
  - Web site launch

A smarter way to get there.



### Welcome!

When your destination is the Harbor East area — there really are smarter ways to get there. You can reduce your carbon footprint — save money on gas, car maintenance, car insurance — and most of all, you can make better use of your commute time to read, listen to music, relax... the possibilities are endless.

"A Smarter Way to Get There" is a transportation initiative of the Waterfront Partnership of Baltimore that promotes

subscribe for updates

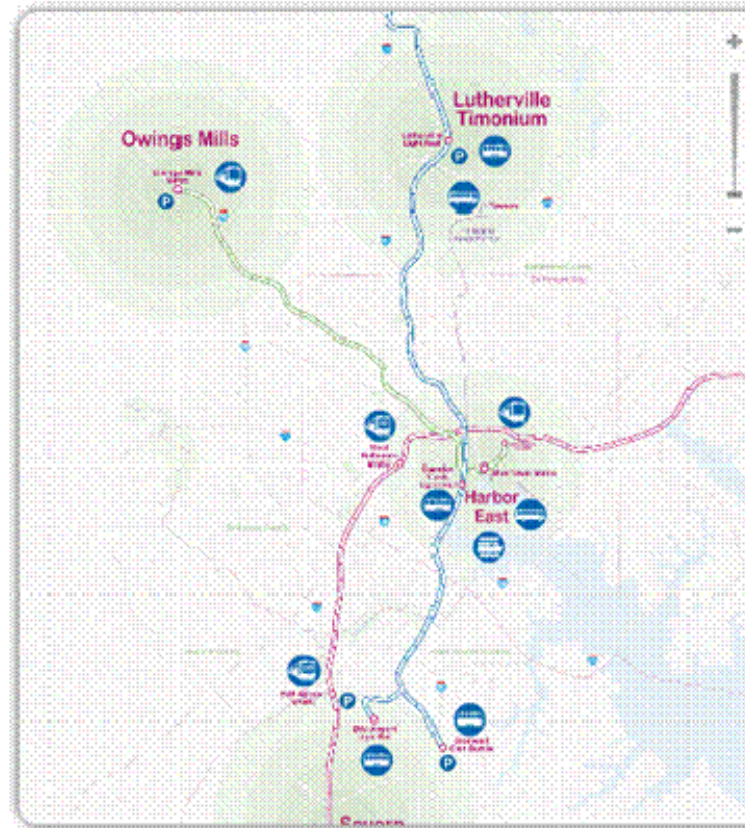

### HOW TO USE THIS SITE



INVEST IN THE FUTURE

A smarter way to: MORE



# Support to Downtown Circulator

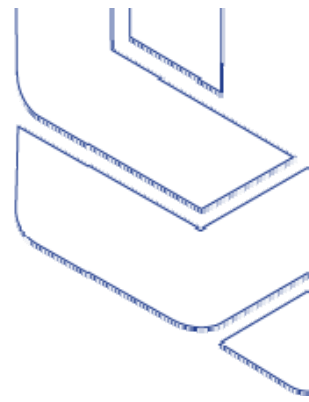

- Customer information pylons and automated passenger counters
- MTA flexed CMAQ funds / provided City with non-federal funds to spend on circulator support (August 2009)
- Change order issued to add automated passenger counters; 5 of 21 buses delivered
- Change order to Veolia contract for bus stop customer information panels; 17 of 70 installed

**TYPE 1  
NEXT BUS  
EXTENDED  
PANEL**

Metal frame  
with vinyl  
graphics  
applied

All Graphics  
fully  
customizable

Top Graphic

Stop Name

Digital Readout

Route Name

Extended  
Panel

Door with  
colored  
metal frame

Bottom  
Graphic

Footer

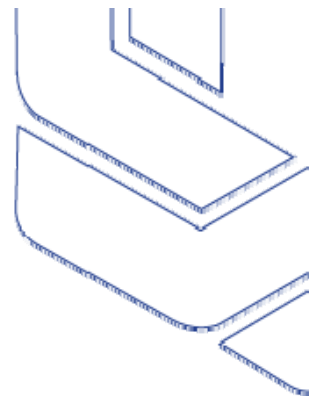

# Baltimore City Signal Timing Optimization

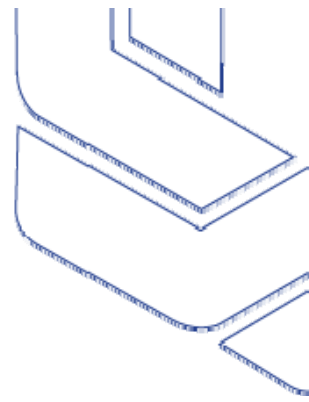

- \$230,000 portion of a larger >\$1 M project city-wide signal timing optimization
- City-wide project: 550 signals (2009-2012)
- Spring 2010 – progress report on implementation



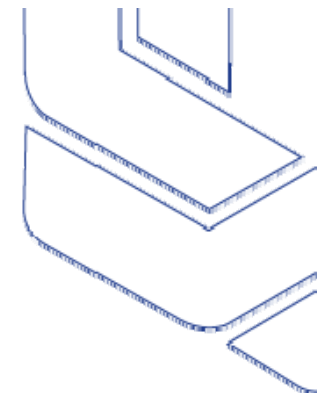
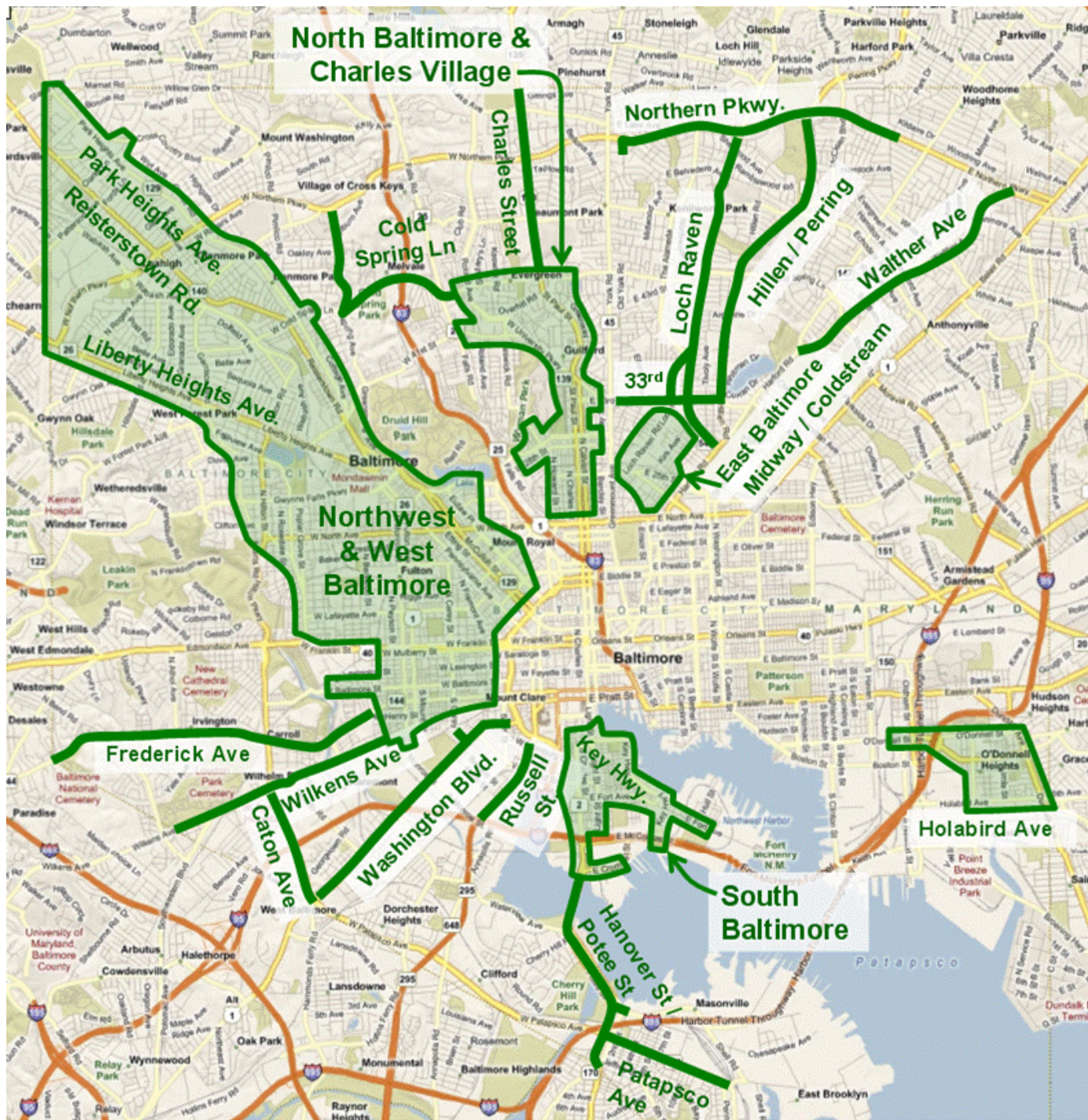

Baltimore Metropolitan Council



# Baltimore City Hybrid Bucket Trucks

- October 2009: 2 hybrid bucket trucks put into service
- Replacing existing 1995 and 1997 conventional vehicles



# Baltimore City Fire Truck Retrofits

- Plans to retrofit fire trucks with EPA-eligible diesel particulate filters.
- Coordinating with experts to determine equipment needed.



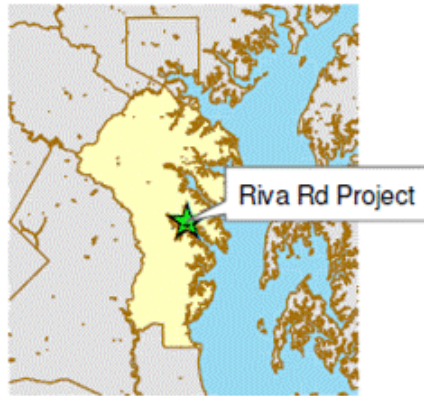

# Anne Arundel County ACS Lite

- To date: Purchase order for engineering and equipment made – all funds obligated.
- Feb 2010: Fiber installation / switchbox update
- End of March/Early April 2010: System online – start of 3-6 month run
- Follow up travel time study



Riva Rd Project



|   |   |   |
|---|---|---|
| <b>Riva Road Traffic Signals</b><br>ACS Lilo Project  |   |  |
| <br>Traffic Engineering Division | Date: 11/20/09<br>Scale: 1 inch = 933 feet<br>Drawn By: NAF |   |

# Howard County Hybrid Transit Buses

- Plans to purchase three diesel electric hybrid buses. Two large buses and one smaller bus.
- MTA will apply for federal funding.
- Once in fleet, CTC to monitor performance.

# City of Westminster Traffic Signal Timing

- April 2009: Consultant performed a traffic signal system evaluation on Main St. (7 intersections) and Green St. (4 intersections)
- Consultant working with SHA on signal timing plan agreement.
- Post-timing evaluation to start end of January 2010.

# Next Steps

- Continue to track all projects.
  - Report back.
  - Document results.



- Utilize feedback to improve process into the future.

# For More Information

Sara Tomlinson

410-732-0500 Ext. 1035

[stomlinson@baltometro.org](mailto:stomlinson@baltometro.org)

[www.baltometro.org](http://www.baltometro.org)

